

**SEAT & FRAMING PLAN**

1/4" = 1'-0"  
20 NET SEATS @ 18" PER SEAT

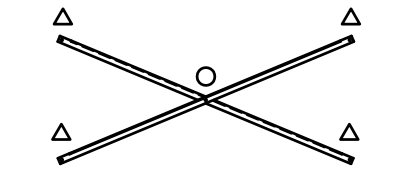

**X-BRACE DETAIL**

N.T.S.

- 7/16" X 1" GALV. MACH. BOLT
- △ 7/16" X 3" GALV. MACH. BOLT

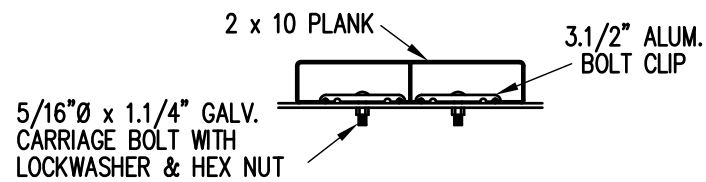

**BOLT CLIP DETAIL**

1.1/2" = 1'-0"

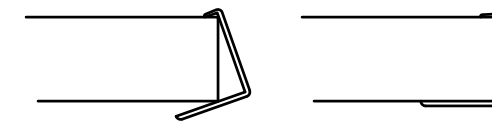

FIG.1

FIG.2

- 1) LOCATE THE CHANNEL END CAP AS SHOWN IN FIG. 1.
- 2) TAP END CAP INTO PLACE WITH RUBBER Mallet OR SOFT WOOD. FIG.2
- 3) DRILL TWO 5/32" HOLES THROUGH THE BOTTOM FLANGE AND THE BOTTOM OUTSIDE PLANK FLANGES. INSTALL TWO 3/16" DRIVE RIVETS. (2 PER PLANK)

**END CAP DETAIL**

N.T.S.

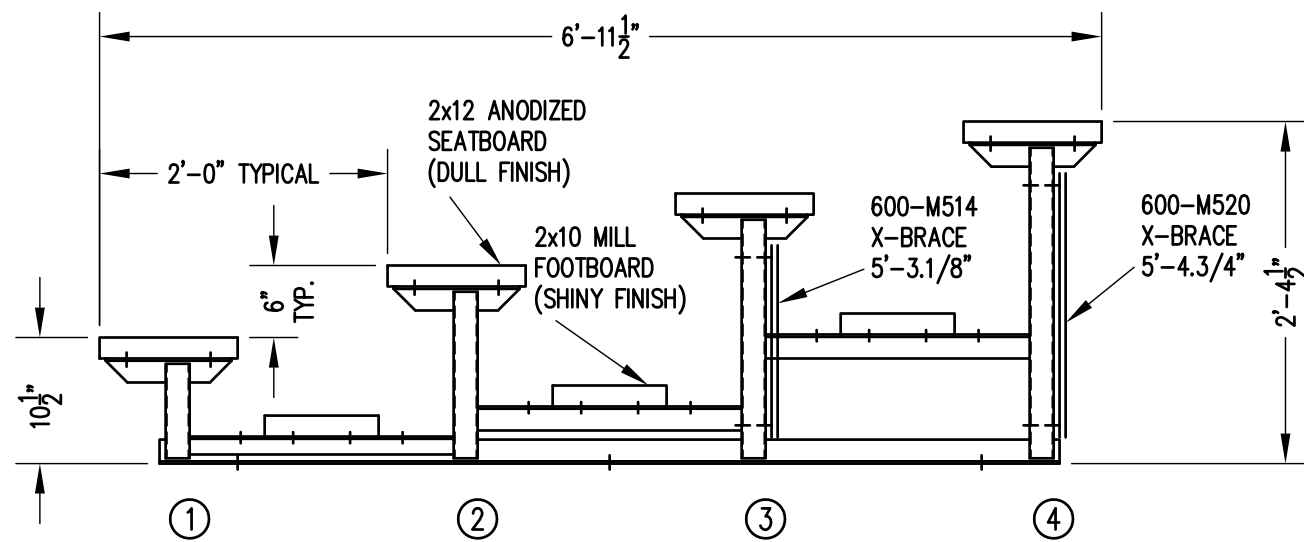

**SECTION AA**

3/4" = 1'-0"

		<b>Outdoor Aluminum</b> P.O. BOX 118 GENEVA, ALABAMA 36340 334-684-2296		
				SCALE
DATE	02/02/09			
DR'N	WJW CKD			
AP'VD				
TITLE	LTSA 4-7.5 SEATING/FRAMING PLAN			NO. <b>864-E1066</b>