

SEAT & FRAMING PLAN

1/4" = 1'-0"
 15 NET SEATS @ 18" PER SEAT

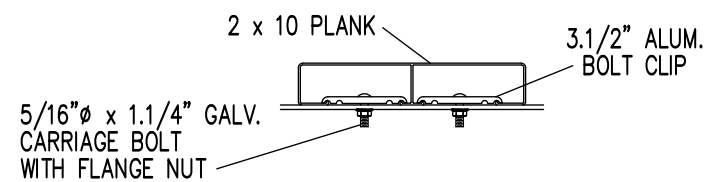

BOLT CLIP DETAIL

1.1/2" = 1'-0"

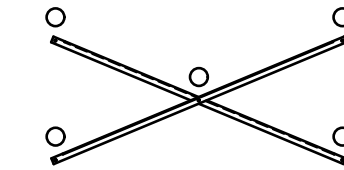

X-BRACE DETAIL

N.T.S.

○ 7/16" X 1" GALV. MACH. BOLT

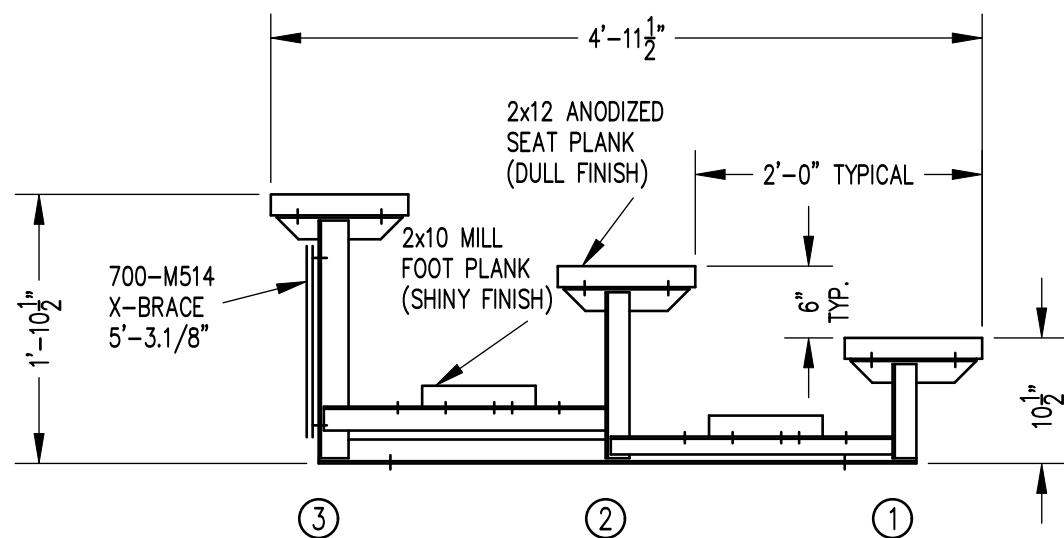

SECTION AA

3/4" = 1'-0"

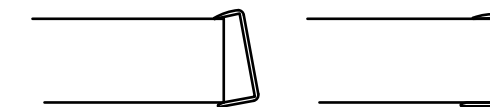

FIG.1

FIG.2

- 1) LOCATE THE CHANNEL END CAP AS SHOWN IN FIG. 1.
- 2) TAP END CAP INTO PLACE WITH RUBBER Mallet OR SOFT WOOD. FIG.2
- 3) DRILL 5/32" HOLES THROUGH THE BOTTOM FLANGE AND THE BOTTOM OUTSIDE PLANK FLANGES OF EACH PLANK. INSTALL 5/32" POP RIVETS.

END CAP DETAIL

N.T.S.

		Outdoor Aluminum P.O. BOX 118 GENEVA, ALABAMA 36340 334-684-2296					
				SCALE	AS NOTED	REVISIONS	
DATE	12/3/08	UPDATED TO 700 SERIES STANDARDS		GDK	02/13		
DR'N	JAW CKD	ADJUSTED FOR FLANGE NUT		GDK	5/24		
AP'VD							
TITLE				NO.			
LSG 3-7.5 SEATING/FRAMING PLAN				564-E1041			