

SEAT & FRAMING PLAN
 1/4" = 1'-0"
 40 NET SEATS @ 18" PER SEAT

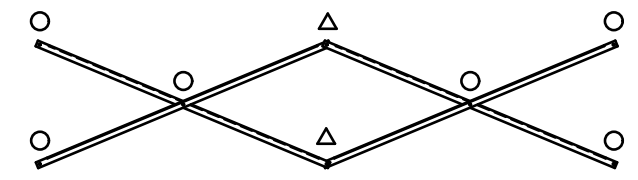

X-BRACE DETAIL
 N.T.S.

- 7/16" X 1" GALV. MACH. BOLT
- △ 7/16" X 1.1/2" GALV. MACH. BOLT

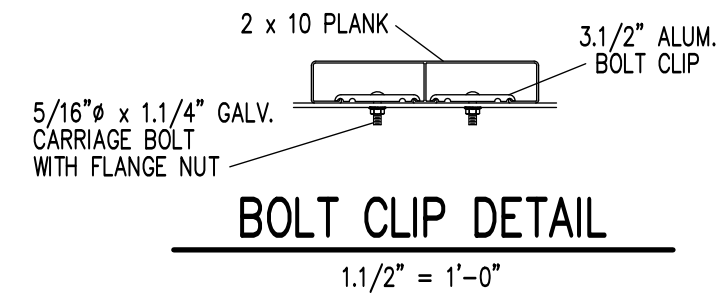

BOLT CLIP DETAIL
 1.1/2" = 1'-0"

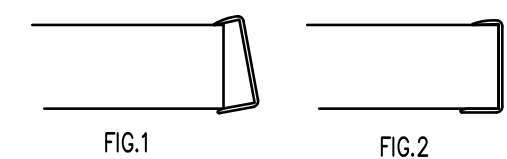

- 1) LOCATE THE CHANNEL END CAP AS SHOWN IN FIG. 1.
- 2) TAP END CAP INTO PLACE WITH RUBBER Mallet OR SOFT WOOD. FIG.2
- 3) DRILL 5/32" HOLES THROUGH THE BOTTOM FLANGE AND THE BOTTOM OUTSIDE PLANK FLANGES OF EACH PLANK. INSTALL 5/32" POP RIVETS.

END CAP DETAIL
 N.T.S.

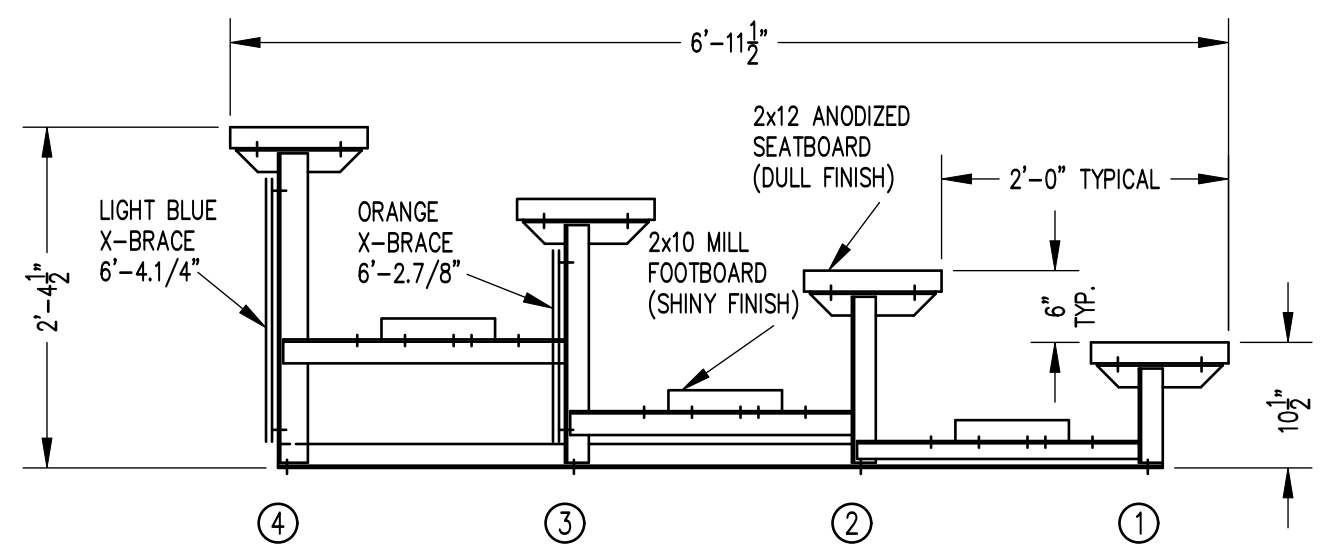

SECTION AA
 3/4" = 1'-0"

		P.O. BOX 118 GENEVA, ALABAMA 36340 334-684-2296					
		SCALE	AS NOTED	REVISIONS		BY	DATE
DATE	12/3/08	UPDATED TO 700 SERIES STANDARDS		GDK	02/13		
DR'N	JAW CKD	ADJUSTED FOR FLANGE NUT		GDK	5/24		
AP'VD							
TITLE						NO.	
LSG 4-15 SEATING/FRAMING PLAN						564-E1076	