

SEAT & FRAMING PLAN
 1/4" = 1'-0"
 42 NET SEATS @ 18" PER SEAT

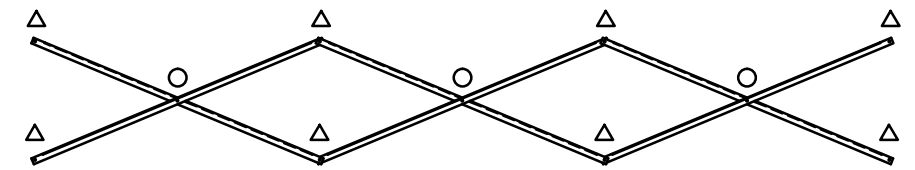

X-BRACE DETAIL
 N.T.S.

○ 7/16" X 1" GALV. MACH. BOLT
 △ 7/16" X 3" GALV. MACH. BOLT

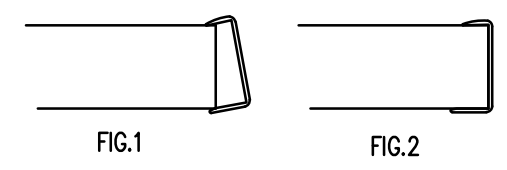
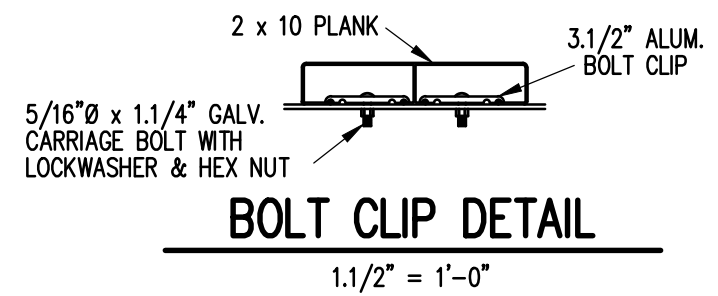

- 1) LOCATE THE CHANNEL END CAP AS SHOWN IN FIG. 1.
- 2) TAP END CAP INTO PLACE WITH RUBBER Mallet OR SOFT WOOD. FIG.2
- 3) DRILL 5/32" HOLES THROUGH THE BOTTOM FLANGE AND THE BOTTOM OUTSIDE PLANK FLANGES OF EACH PLANK. INSTALL 5/32" POP RIVETS.

END CAP DETAIL
 N.T.S.

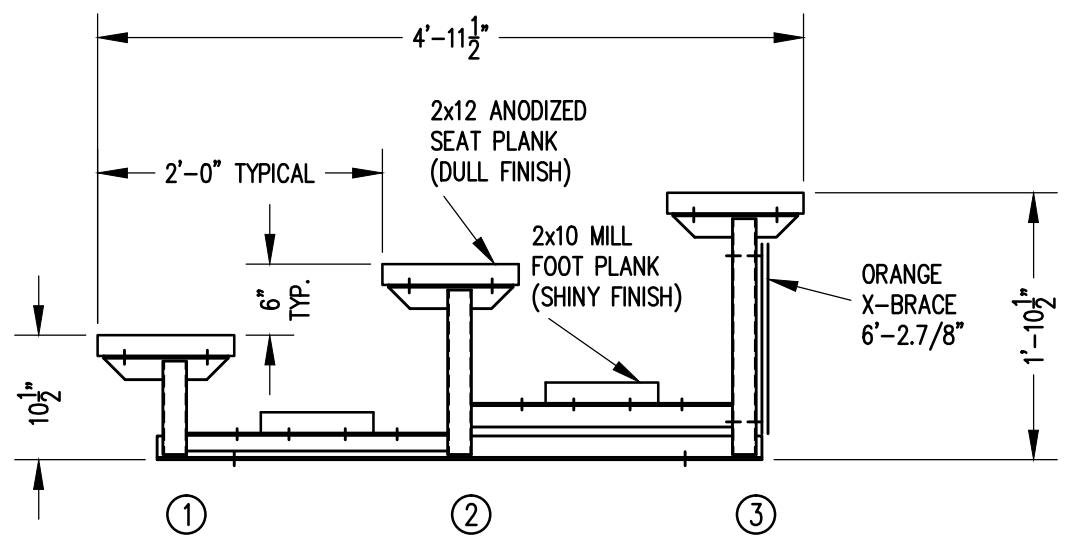

SECTION AA
 3/4" = 1'-0"

| | | | | | |
|--------------------------------|----------|--|--|----------------|-----------|
| | | Outdoor Aluminum P.O. BOX 118 GENEVA, ALABAMA 36340 334-684-2296 | | | |
| | | | | SCALE AS NOTED | REVISIONS |
| DATE | 02/02/09 | UPDATED TO 700 SERIES STANDARDS | | GDK | 02/13 |
| DR'N | WHW | CKD | | | |
| AP'VD | | | | | |
| TITLE | | | | NO. | |
| LTSA 3-21 SEATING/FRAMING PLAN | | | | 864-E1056 | |