

SWIVEL CASTOR ATTACH W/ (4) 3/8" x 7/8" GALV. MACHINE BOLT, FLAT WASHER & HEX NUT, TYP.

FIXED CASTOR ATTACH W/ (4) 3/8" x 7/8" GALV. MACHINE BOLT, FLAT WASHER & HEX NUT, TYP.

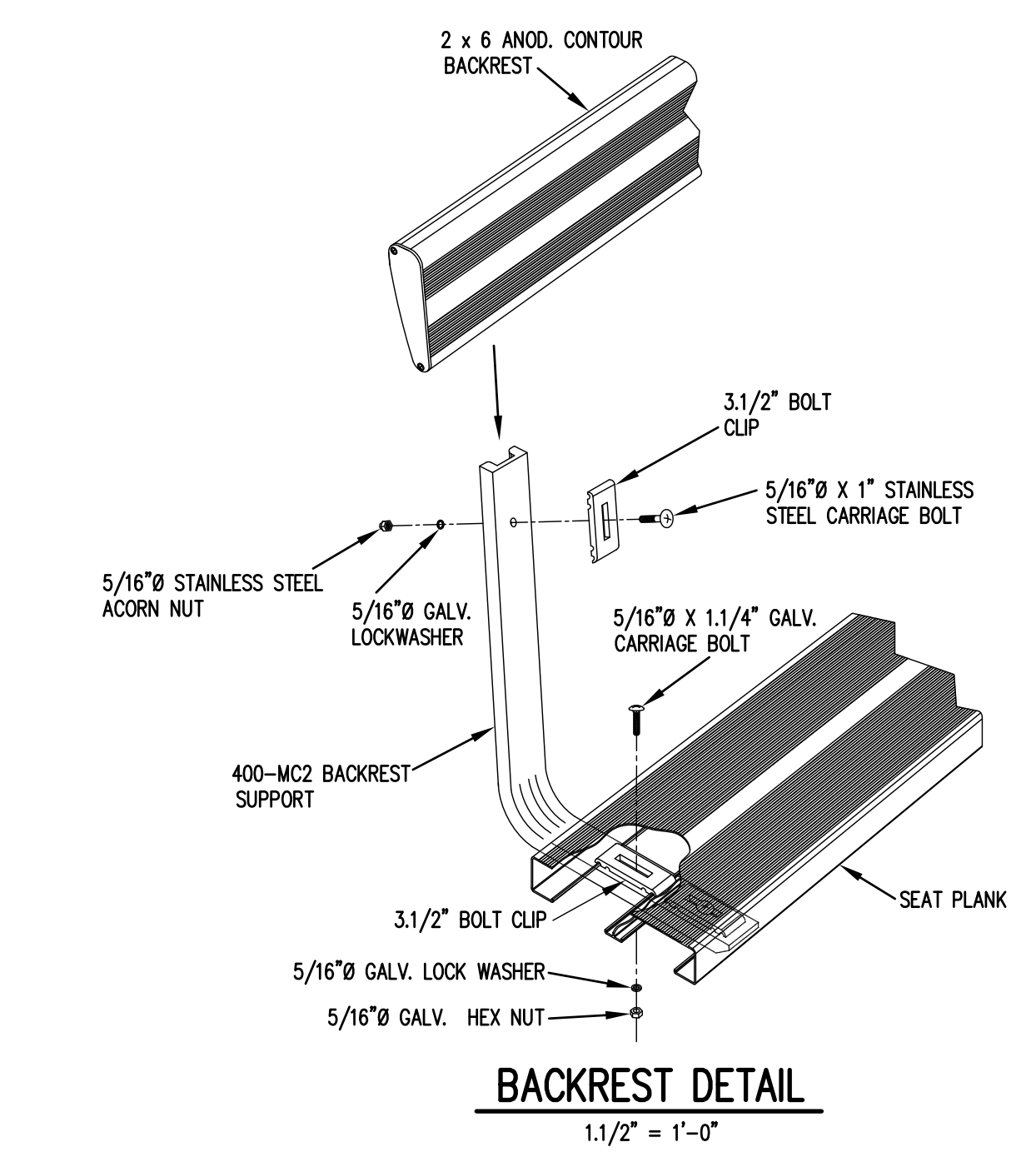

BOLT CLIP SCHEDULE	
3,1/2" BOLT CLIP REQUIRED FOR	2,1/2" BOLT CLIP REQUIRED FOR
2 x 12 PLANK	2 x 8 PLANK
2 x 10 PLANK	2 x 12 STEP
2 x 6 BACKREST	2 x 8 AISLE

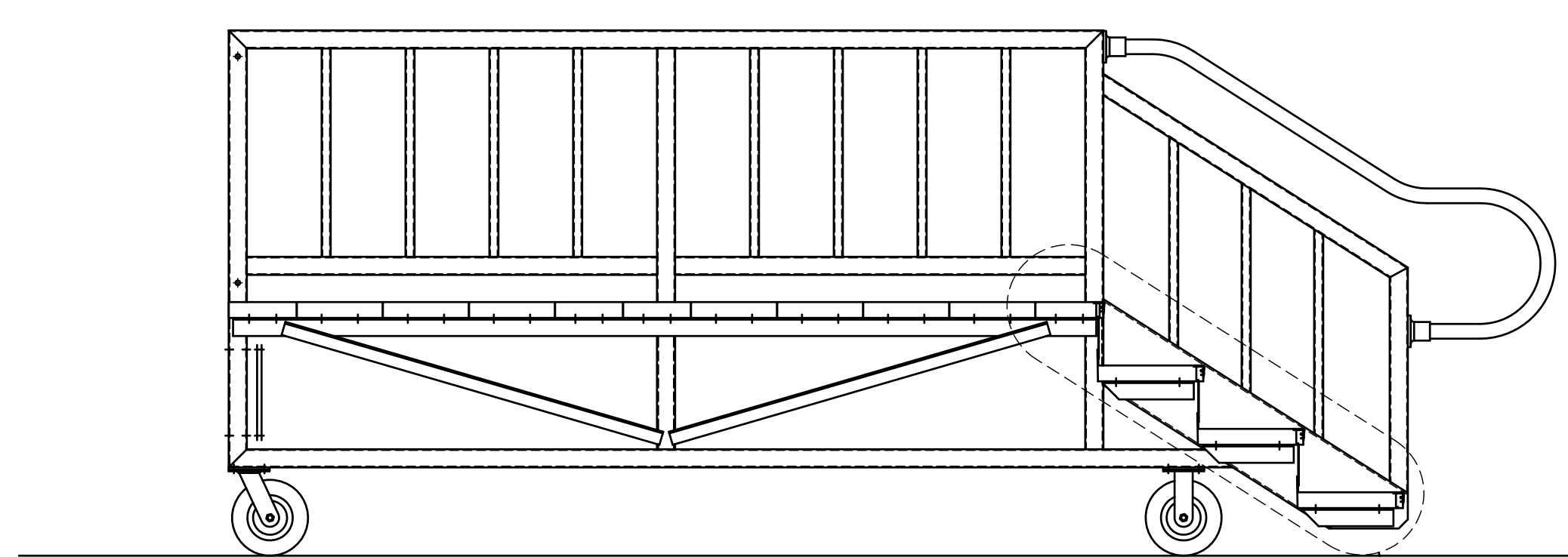
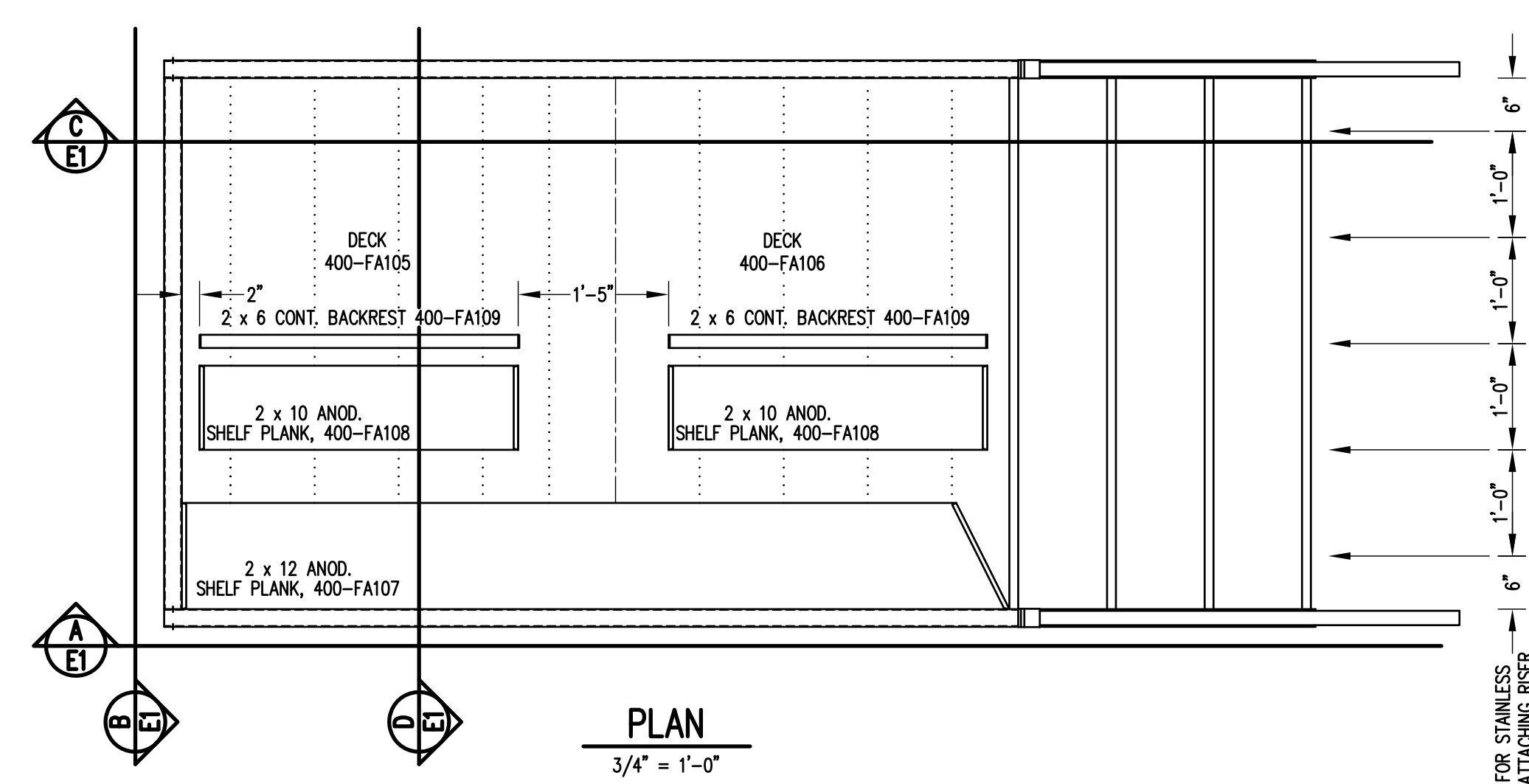
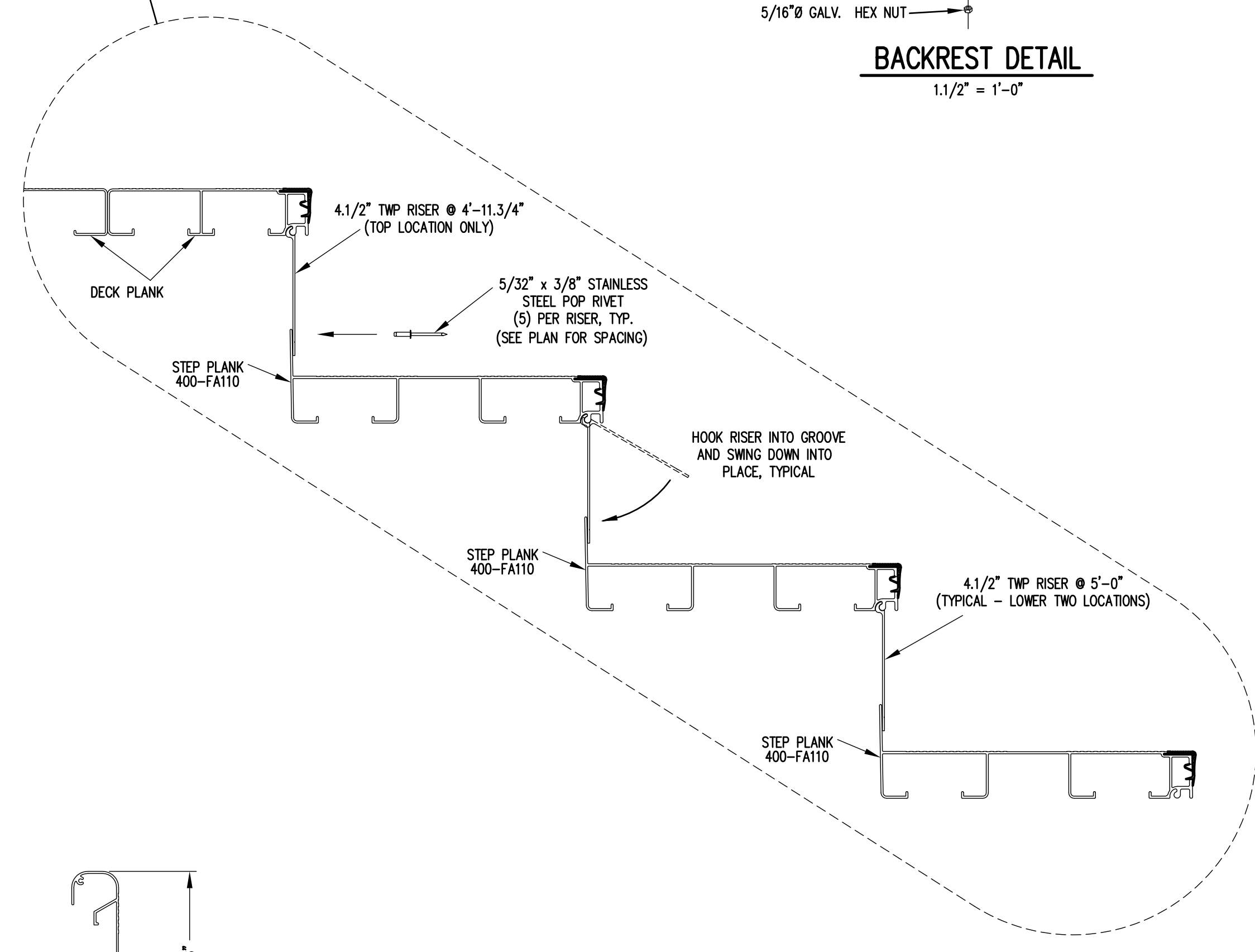

ASSEMBLY SEQUENCE

FAMILIARIZE YOURSELF WITH PROVIDED DRAWINGS AND DETAILS AND PROCEED AS FOLLOWS:

- ASSEMBLE X-BRACE TOGETHER WITH CENTER BOLT.
- ATTACH X-BRACE TO FRAME 400-FA101.
- ATTACH FRAME 400-FA102 TO X-BRACE.
- INSTALL GUARDRAIL 400-FA103 BETWEEN FRAMES.
- INSTALL CASTORS AT LOCATIONS SHOWN. NOTE: FIXED CASTORS SHOULD BE INSTALLED WITH BRAKE LEVER TO THE OUTSIDE.
- PLACE DECK SECTIONS 400-FA105 AND 400-FA106 INTO POSITION, SQUARE FRAMES AS REQUIRED, AND ATTACH WITH BOLT CLIP ASSEMBLIES.
- LOCATE ALL STEP PLANK INTO POSITION, LOOSELY ATTACHING BOLT CLIP ASSEMBLIES, BEGINNING WITH THE TOP STEP. THE LEADING LOWER EDGE OF THE PLANK SHOULD OVERHANG THE FRONT OF EACH SUPPORT ANGLE BY ONE INCH.
- PULL EACH FRAME TIGHTLY TO EDGE OF STEP PLANK AND TIGHTEN BOLT CLIPS. NOTE: THIS IS MOST EASILY ACCOMPLISHED BY SURROUNDING A RATCHET STRAP AROUND THE LOWER STAIR CHANNELS AND PULLING SNUG.
- INSTALL WDS RISER ON STEPS - SEE SECTION DETAIL C-E1 AND RIVET. LOCATION SPACING ON PLAN. RIVETS REQUIRE A 5/32" HOLE.
- SLIDE STAIR HANDRAILS 400-HR101 INTO SOCKETS ON 400-FA101 AND 400-FA102, AND LOCK INTO PLACE WITH SET SCREWS LOCATED ON UNDERSIDE OF EACH SOCKET.
- PLACE SHELF 400-FA107 INTO POSITION AND ATTACH WITH BOLT CLIP ASSEMBLIES.
- PLACE (4) SEAT SUPPORTS 400-FA104 INTO POSITION AND FASTEN WITH 5/16" x 3" CARRIAGE BOLTS, LOCK WASHERS, HEX NUTS, AND BACKER ANGLE 400-MA102 AS SHOWN.
- PLACE SEAT PLANK 400-FA108 ONTO LOCATION PER DRAWING AND ATTACH WITH BOLT CLIP ASSEMBLIES.
- INSTALL BACKREST SUPPORTS 400-MC2 AND BACKREST PLANK PER DRAWING.

RECOMENDED TOOLS

- (2) 9/16" COMBINATION WRENCH
- 5/8" COMBINATION WRENCH
- 11/16" COMBINATION WRENCH
- 1/2" DEEP SOCKET WITH RATCHET & SHORT EXTENSION
- 1/2" COMBINATION WRENCH
- 3/16" ALLEN WRENCH
- 12"-14" RATCHET STRAP
- POWER DRILL
- 5/32" CUTTING DRILL BIT
- POP RIVET GUN

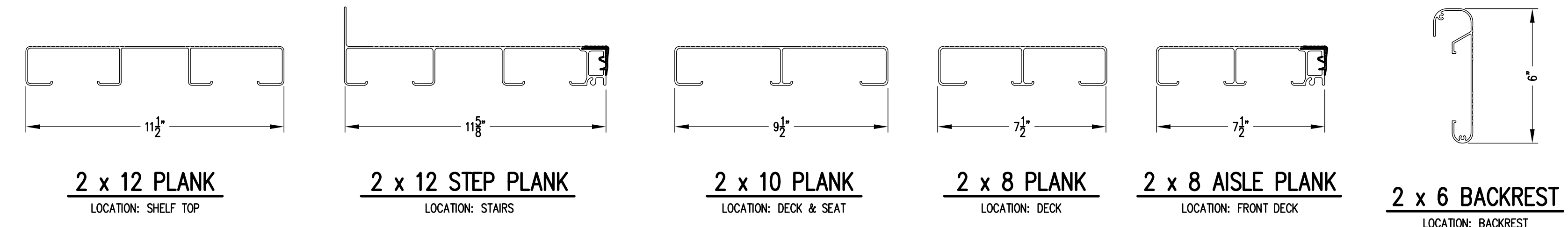

THIS MATERIAL IS OWNED BY AND IS THE SOLE AND EXCLUSIVE PROPERTY OF THE OUTDOOR ALUMINUM COMPANY, INC., AND IS SUPPLIED TO THE OWNER ON A CONFIDENTIAL BASIS, SOLELY FOR USE IN CONNECTION WITH THE PROJECT LISTED AT RIGHT. FEDERAL LAW PROHIBITS THE REPRODUCTION, DISPLAY, SALE OR OTHER DISPOSITION OF THESE DOCUMENTS WITHOUT THE EXPRESS WRITTEN CONSENT OF THE OUTDOOR ALUMINUM COMPANY.

		P.O. BOX 118 GENEVA, ALABAMA 36340 334-694-2266	
SCALE: AS NOTED	REVISIONS:	BY:	DATE:
DATE: 12/11/15			
DRN: GDL			
APVD:			
TITLE: SCORER'S PLATFORM ERECTION PLAN		NO: 400-E1	