

PLEASE READ THROUGH INSTRUCTIONS ONCE BEFORE ASSEMBLING

(1) SLIP ON CHANNEL END CAPS (ONE ON EACH END OF PLANK). IF NECESSARY, TAP LIGHTLY WITH A WOOD BLOCK OR RUBBER Mallet. TAP ONLY ON THE CORNERS OF THE CHANNEL END CAPS. LONG LEG OF CHANNEL END CAPS SHOULD BE PLACED ON THE UNDERSIDE OF PLANK. DRILL 5/32"Ø HOLES THROUGH CHANNEL END CAPS AND PLANK AS SHOWN ON DRAWING AND ATTACH WITH POP RIVETS. REPEAT ON OTHER END.

(2) PLACE MCTS FRAMES ON FIRM LEVEL GROUND APPROXIMATELY SIX FEET APART. ATTACH HORIZONTAL BRACE TO FRAMES AS SHOWN ON DRAWING WITH 7/16" x 3" MACHINE BOLTS AND 7/16"Ø HEX NUTS. FRAME BAYS WITHOUT HORIZONTAL BRACES SHOULD NOT EXCEED 6'-0".

(3) PLACE 2 x 12 SEAT PLANK AGAINST MCTS FRAMES SO THAT PLANK DOES NOT OVERHANG THE END MOST FRAMES MORE THAN 1'-6" (3" MIN. TO 1'-6" MAX.). SEE DRAWING FOR FURTHER CLARIFICATION. ATTACH SEAT PLANK TO MCTS FRAMES USING 2 BOLT CLIPS, 5/16" x 3" CARRIAGE BOLTS, LOCK WASHERS AND HEX NUTS. MAKE SURE THAT FRAMES ARE PERPENDICULAR TO SEAT PLANK. SEE BOLT CLIP DETAIL.

(4) PLACE 2 x 10 BACKREST PLANK AGAINST MCTS FRAMES SO THAT PLANK DOES NOT OVERHANG THE END MOST FRAMES MORE THAN 1'-6" (3" MIN. TO 1'-6" MAX.). SEE DRAWING FOR FURTHER CLARIFICATION. ATTACH BACKREST PLANK TO MCTS FRAMES USING 2 BOLT CLIPS, 5/16" x 3" CARRIAGE BOLTS, LOCK WASHERS, AND HEX NUTS. MAKE SURE THAT FRAMES ARE PERPENDICULAR TO BACKREST PLANK. SEE BOLT CLIP DETAIL.

(5) TIGHTEN ALL BOLTS.

(6) MOVE ASSEMBLED BENCH TO FINAL LOCATION. ATTACH TO CONCRETE WITH PROVIDED ANCHORS.

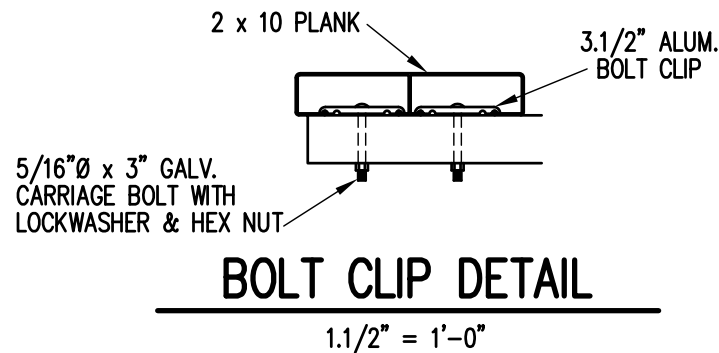
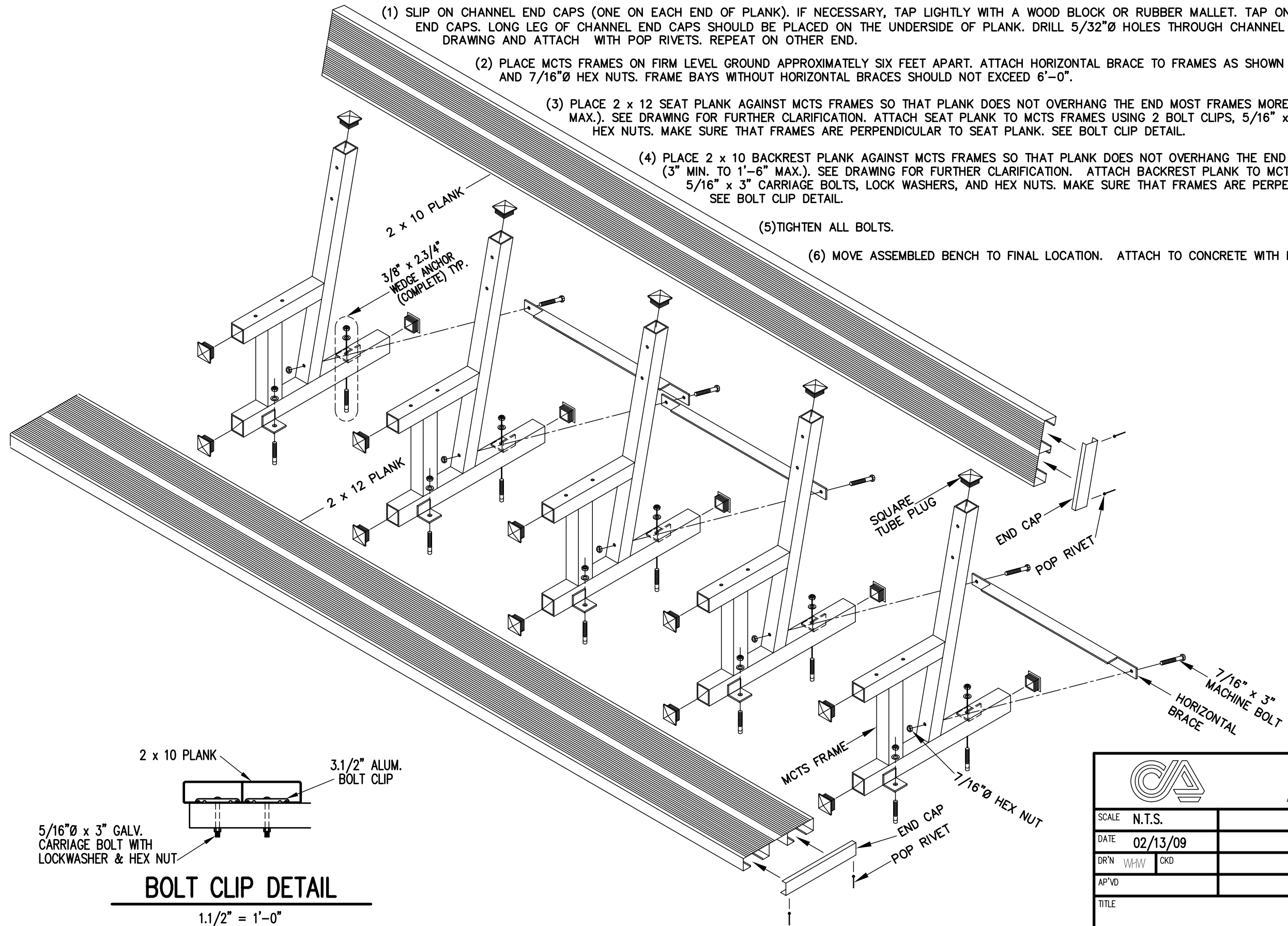

		Outdoor Aluminum P.O. BOX 118 GENEVA, ALABAMA 36340 334-684-2296		
				SCALE
DATE	02/13/09			
DR'N	WJW CKD			
AP'VD				
TITLE	MCTS BENCH W/ANCHORS			NO. 300-E150