

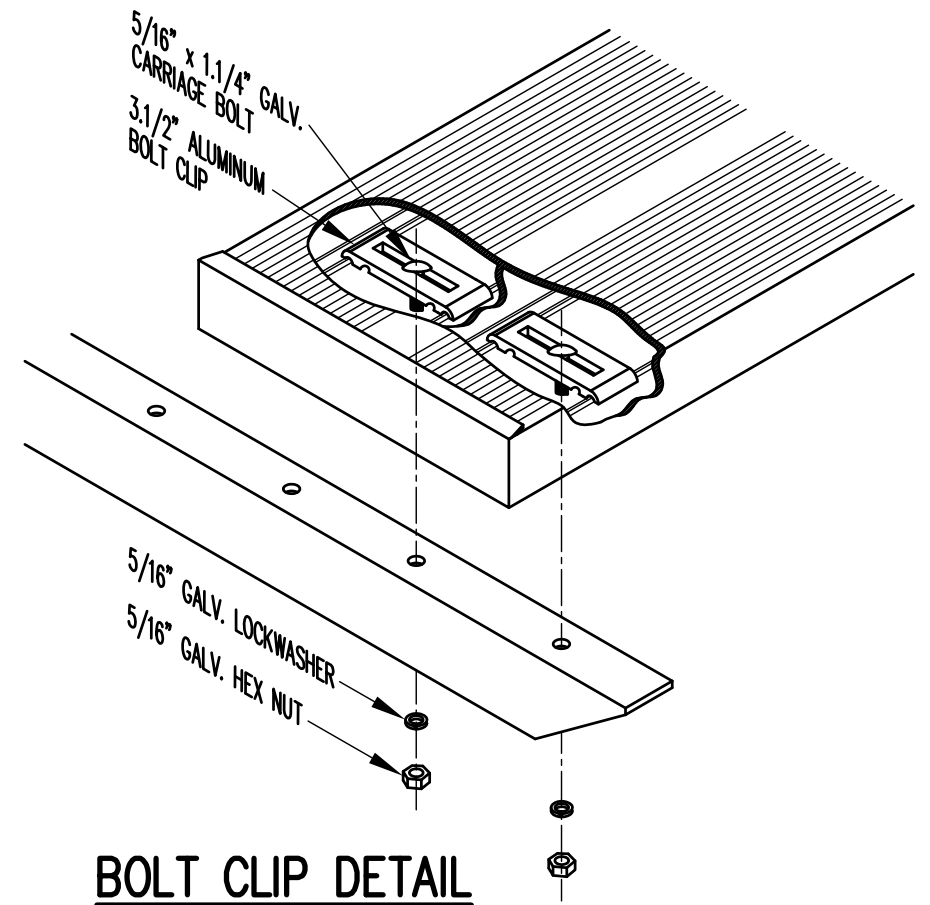

TFS PICNIC TABLE

(TABLE FRAME SQUARE)

- (1) PLACE TABLE TOP UP-SIDE-DOWN ON GROUND.
- (2) POSITION TABLE FRAMES ON TABLE TOP ALLOWING THE FOLLOWING PLANK OVERHANG: TFS-6 (0'-6"), TFS-7.5 (0'-9"), TFS-8 (1'-0"). SQUARE EACH FRAME TO THE TABLE TOP AND ATTACH WITH BOLT CLIP ASSEMBLIES AS SHOWN.
- (3) ATTACH FIRST DIAGONAL BRACE TO FRAME AS SHOWN WITH 7/16" x 3" MACHINE BOLT.
- (4) ATTACH OTHER END OF DIAGONAL BRACE TO TABLE TOP WITH BOLT CLIP ASSEMBLIES AND TIGHTEN.
- (5) REPEAT FOR OTHER DIAGONAL BRACE.
- (6) TURN TABLE RIGHT-SIDE-UP. POSITION SEAT PLANK ONTO FRAMES, ALIGN WITH ENDS OF TABLE TOP AND ATTACH WITH BOLT CLIP ASSEMBLIES.

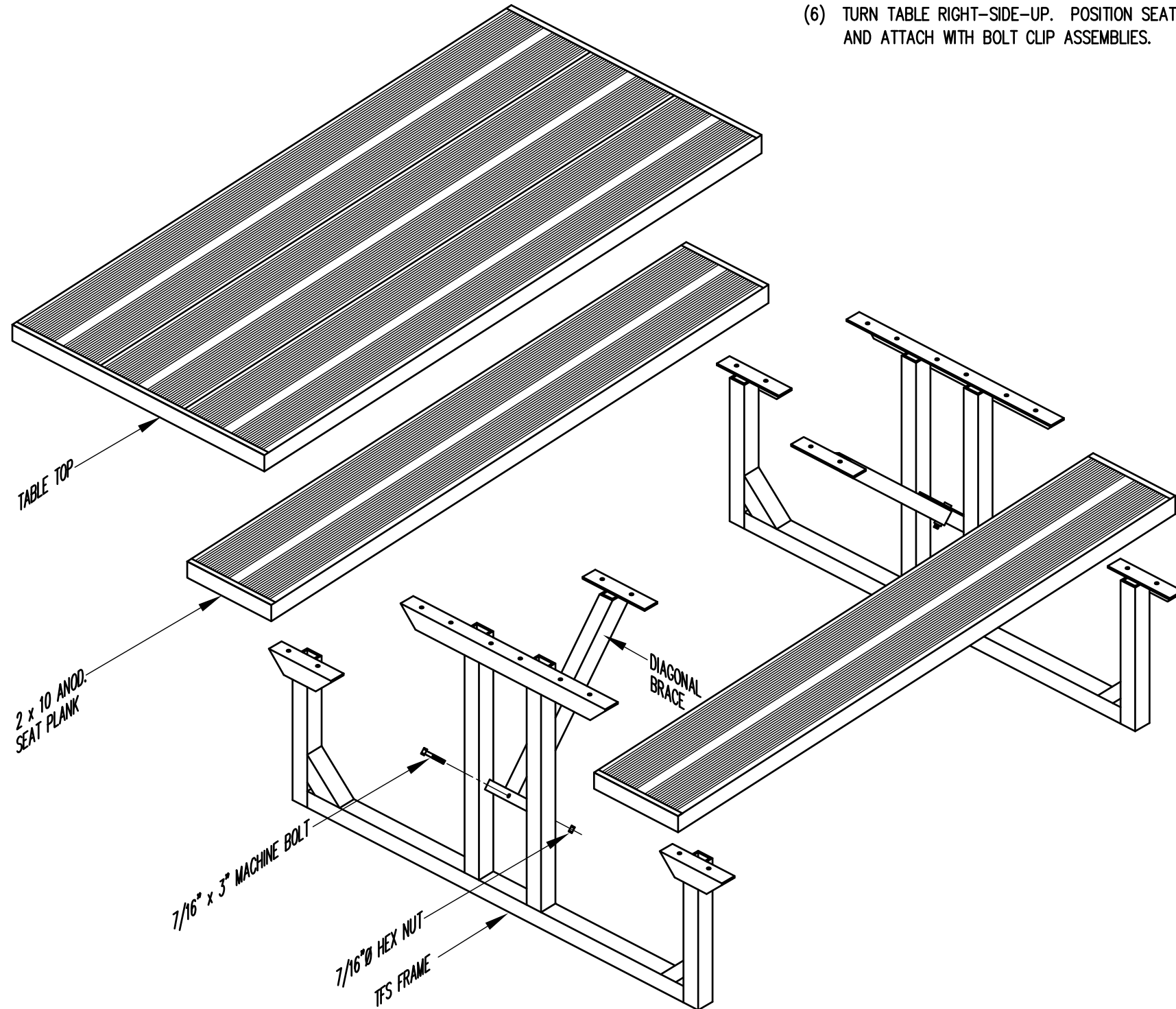

		Outdoor Aluminum P.O. BOX 118 GENEVA, ALABAMA 36340 334-684-2296			
				SCALE	3/4"=1'-0"
DATE	11/30/04	UPDATED INSTRUCTIONS		GDK	01/07
DR'N	RLH	CKD			
AP'VD					
TITLE				NO.	
TFS PICNIC TABLE				350-E1	